

## Angled End Milling Machine for AL profiles

Koncová fréza Automatická s Nastavením uhlov pre AL

Osztóborda Végmaró Automata AL profilokhoz, gyors szögbeállítás

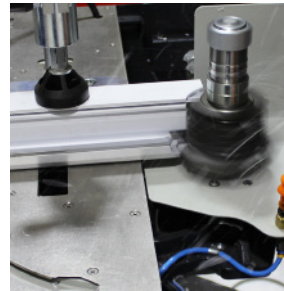

### End Milling:

- Support system adjustable to four different profiles
- High quality end milling thanks to hydropneumatic system



### Cutter Change System:

- Practical cutter change system provides ease of operation.



### Flat Cutter End Milling:

- End milling with flat cutter at  $-22,5^\circ$ ,  $+45^\circ$  range



### Reverse Cutter End Milling:

- End milling with flat cutter at  $-22,5^\circ$ ,  $-45^\circ$  range

### General Features

Všeobecné charakteristiky - Általános jellemzők

- End milling of PVC profiles at  $-22,5^\circ$   $+22,5^\circ$  range.
- Angle adjustment with mechanical support plates.
- Practical cutter progress speed adjustment.
- Safe operation with safety cover.
- Practical cutter adjustment thanks to cutter gab.
- Cutter storing with cutter shelf.

- Osztó végmaró PVC profilokhoz,  $-22,5^\circ$  és  $+22,5^\circ$  közt
- Állítható fokok, mechanikus ütközővel
- Könnyen állítható sebesség
- Biztonságos működés
- Gyors marószerszám csere
- Polc a marószerszám tárolására

### Optional Equipments - OPCIE - Doplnkové vybavenie – OPCIÓK - Kiegészítő felszerelés



- End Milling Cutters

- Koncová fréza pre PVC profily medzi  $-22,5^\circ$  a  $+22,5^\circ$
- Jednoduché nastavenie uhlov pomocou mech. dorazu
- Jednoduché nastavenie rýchlosti
- Bezpečná prevádzka s bezpečnostnými krytmi
- Rýchlo výmenný systém výmeny fréz
- Praktické police na skladovanie fréz

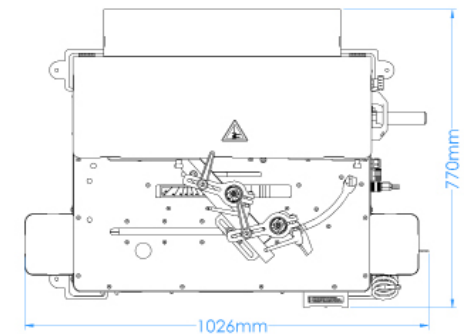
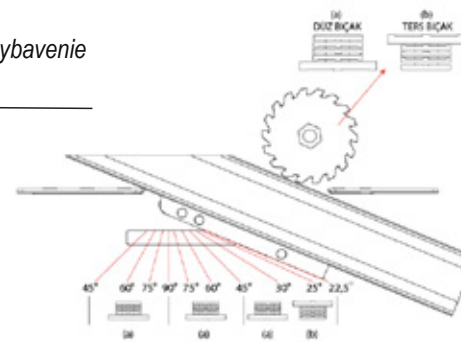

<p>L = 1026 mm W = 770 mm H = 980 mm</p>	<p>400 V L1-L2-L3-N-PE 50 / 60 Hz 1,5 kW</p>	<p>110 kg</p>	<p>6-8 Bar 45 l / Cycle</p>	<p>a max. = 180 mm h max. = 200 mm</p>	<p>ØD: 180 mm Ød: 30 mm h max: 145 mm</p>
--	--	---------------	---------------------------------	--	---