



**Flat Cutter End Milling:**

- End milling with flat cutter at  $-22,5^\circ$ ,  $+45^\circ$  range.



**Reverse Cutter End Milling:**

- End milling with reverse cutter at  $-22,5^\circ$ ,  $-45^\circ$  range.



**Cutter Change System:**

- Practical cutter change system provides ease of operation.

**End Milling:**

- Support system adjustable to four different profiles.
- High quality end milling thanks to hydropneumatic system.

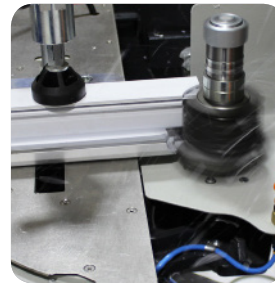

## General Features

- End milling of PVC profiles at  $22,5^\circ$   $+22,5^\circ$  range.
- Angle adjustment with mechanical support plates.
- Practical cutter progress speed adjustment.
- Safe operation with safety cover.
- Practical cutter adjustment thanks to cutter gab.
- Cutter storing with cutter shelf.

## Optional Equipments



• Corner Cleaning Cutters



• End Milling Cutters

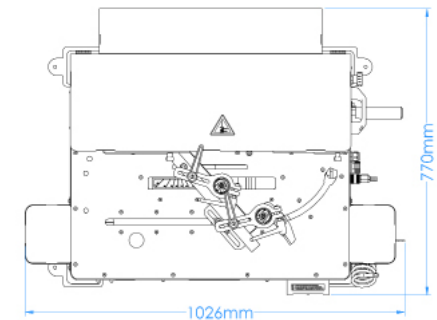
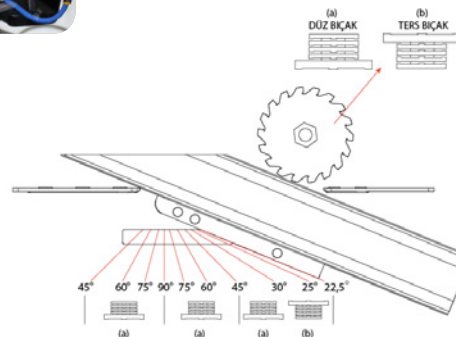

 H: 980 mm	 400 V L1-L2-L3-N-PE 50 / 60 Hz 1.5 kW	 110 kg	 6-8 Bar 45 l / Cycle	 a max: 180mm h max: 200 mm	 ØD: 180 mm Ød: 30 mm h max: 145 mm
---------------	--	------------	-----------------------------	-----------------------------------	--