

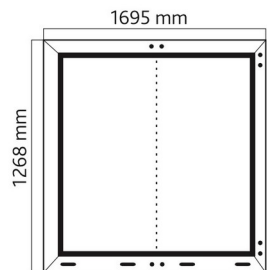

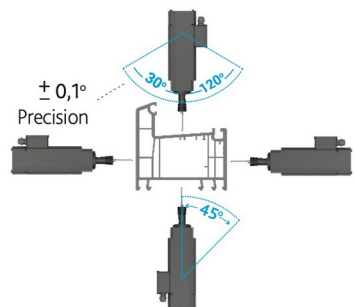

Capacity information





Kapacita výroby – Kapacitás áttekintés

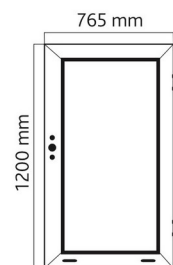
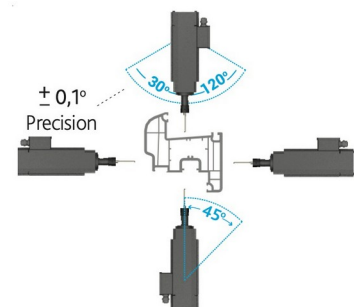

Frame	Processing Time	Profile Length Quan-	Processed Running Meter	Process Symbols	Process Names
1 Frame	72,5 sn.				+/-30°Cutting
10 Frame	12 m 5 s	10			Water Slot
397 Frame	8 Hour	571	3426		Striker
					Mullion Connector Hole

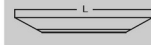



Calculated by processing 10 bars of frame profiles.
 Vypočítané podľa spracovania 10 tyčí rámových profilov.
 10 szál tok profil megmunkálásával kiszámítva.

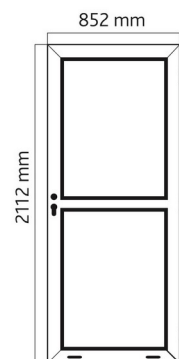
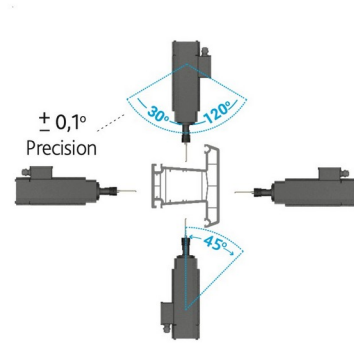

Sash	Processing Time	Profile Length Quan-	Processed Running Meter	Process Symbols	Process Names
1 Frame	61,5 s				+/-30°Cutting
10 Frame	10 m 15 s	6,66			Water Slot
468 Frame	8 Hour	422	2532		Striker
					Window Handle Holes

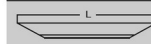
Calculated by processing 10 bars of frame profiles.
 Vypočítané podľa spracovania 10 tyčí krídlových profilov.
 10 szál szárny profil megmunkálásával kiszámítva.



Door	Processing Time	Profile Length Quan-	Processed Running Meter	Process Symbols	Process Names
1 Frame	77,5 s				+/-30°Cutting
10 Frame	12 m 55 s	10			Water Slot
371 Frame	8 Hour	502	3012		Striker
					Cylinder Hole Espagnolette Can
					Mullion Connector Hole

Calculated by processing 10 bars of frame profiles.
 Vypočítané podľa spracovania 10 tyčí dverových profilov.
 10 szál ajtó profil megmunkálásával kiszámítva.